

NOTES (UNLESS OTHERWISE SPECIFIED):

1. OPTIONS:

A. MOUNTING FOOT TYPE:

- PART NUMBER DFS-00281-007-1: ITEM B INSTALLED (COMBO MOUNT FOOT),
- PART NUMBER DFS-00281-007-2: THIS PART NUMBER IS NO LONGER USED.

2. MATERIAL: TYPE 316 STAINLESS STEEL, #14 GAGE (.0747 THICK), TYPE 316 STAINLESS STEEL, #13 GAGE (.090 THICK) ON REAR PANEL, AND AND WHERE NECESSARY TO EASE FABRICATION.



3. FINISH: WHITE ENAMEL PAINT ON ALL EXTERIOR SURFACES. ALL SURFACES SHALL BE CLEANED AND ETCHED PRIOR TO PAINTING.

4. INSTALL ONE EBERHARD LOCKING DRAW LATCH (P/N 750-SSP) AND ONE EBERHARD DRAW LATCH (P/N 750-SS)

5. AS SHOWN USING SIX STAINLESS STEEL BLIND RIVETS.

6. REFERENCE DIMENSION FOR ENCLOSURE OPENING IS 21.12x24.00 +/- .03.

7. MARK PART NUMBER AND REVISION LETTER "DFS-00281-007-01 REV K" WITH BLACK INK ON THE INSIDE SURFACE OF THE DOOR.

 DATA FLOW SYSTEMS, INC. MELBOURNE, FL		DFS-00281-007-1	
DRAWN: 	TITLE:	ENCLOSURE -	REV.
CHKD: XXXX	10 FUNCTION-MODULE RTU		K
ENGR: XXXX	RTU210		
DATE: 03/24/06	SCALE: 1/6	SHEET: 1 OF 2	

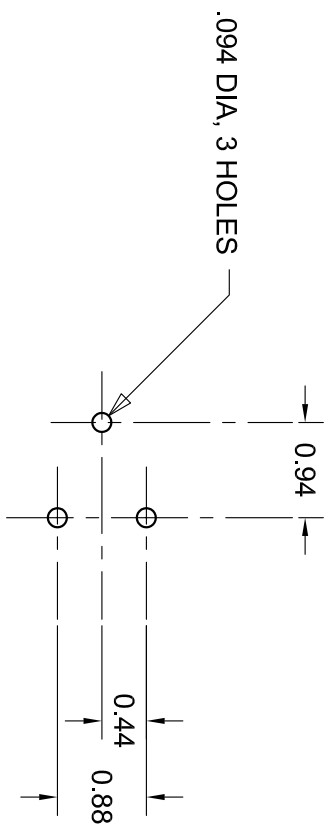

DETAIL A

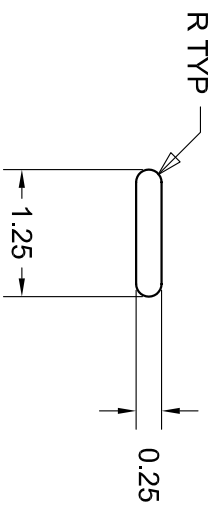

ITEM C

1 REQ'D

MATERIAL: #14 GAGE (.0747 THICK) 316 ST. ST.

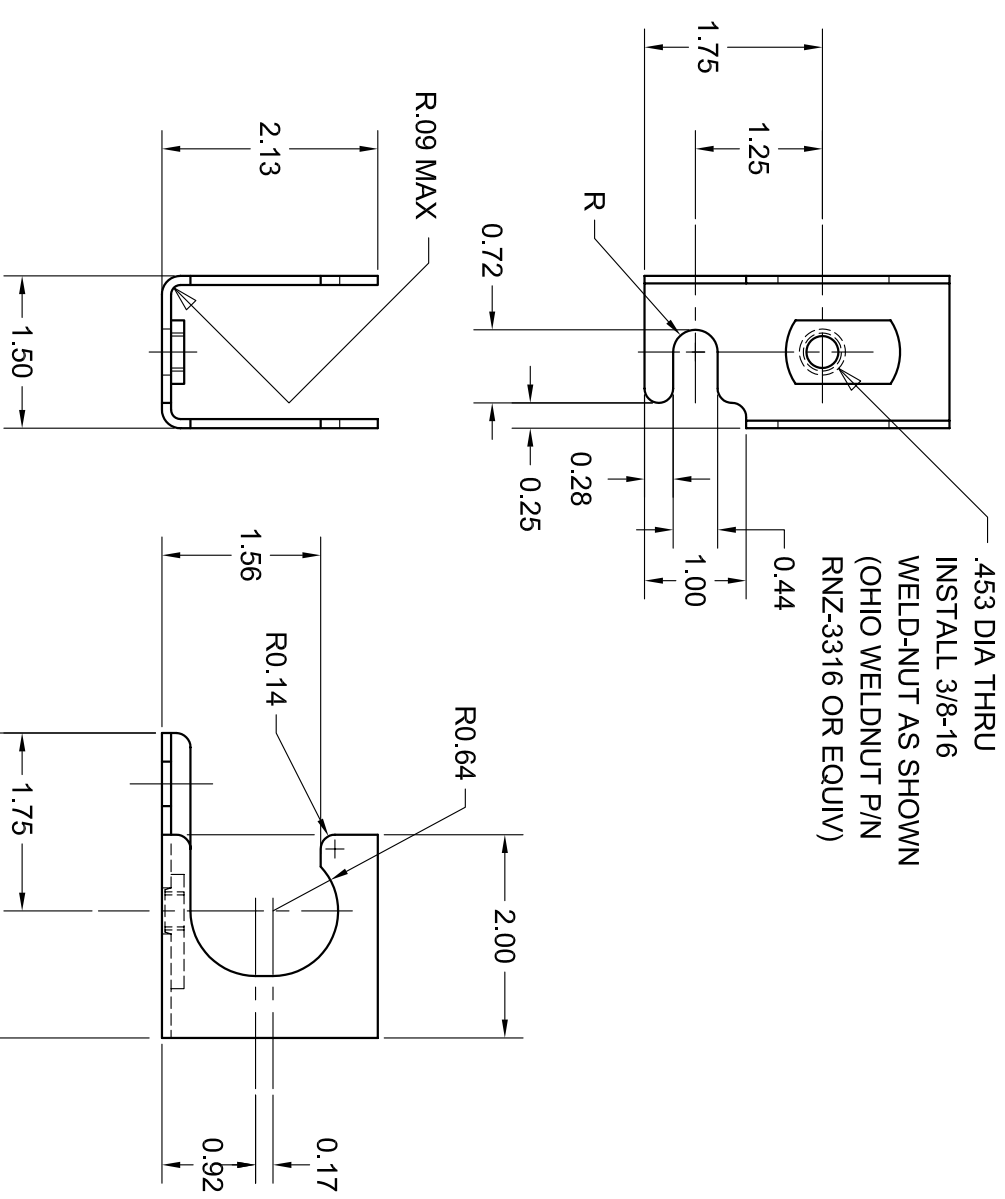
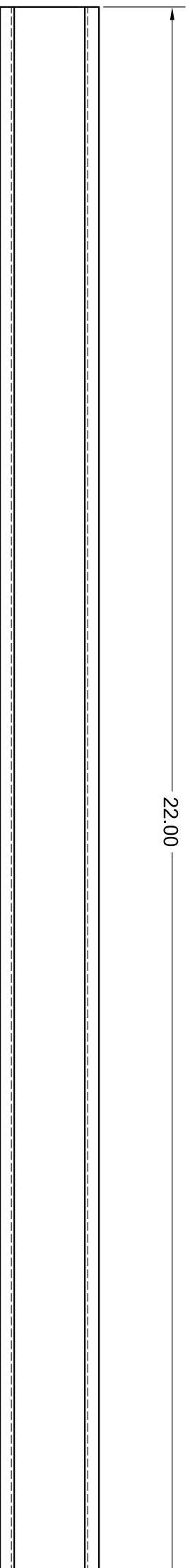

ITEM B

4 REQ'D

MATERIAL: #13 GAGE (.0897 THICK) 316 ST. ST.

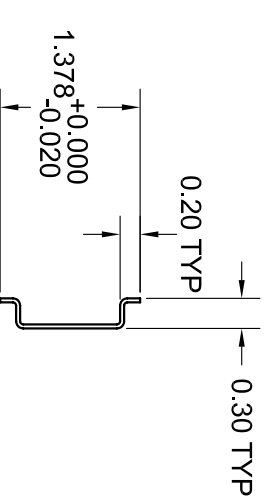

ITEM E

1 REQ'D

MATERIAL: #20 GAGE (.0359 THICK) 316 ST. ST.
REMOVE BURRS AND ROUGH EDGES



DATA FLOW SYSTEMS, INC.
MELBOURNE, FL

DFS-00281-007-1

DRAWN:

TITLE: ENCLOSURE -

REV.

CHKD: X.X.X

10 FUNCTION-MODULE RTU

ENGR: X.X.X

RTU210

K

DATE: 03/24/06

SCALE: 1/2

SHEET: 2 OF 2